

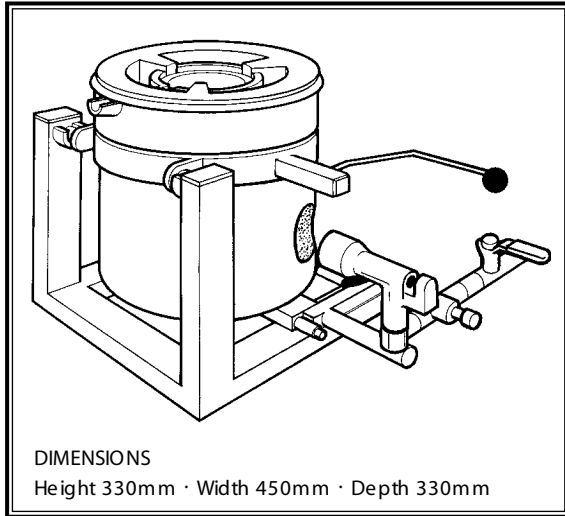

CM 350

SAFETY TILT CRUCIBLE FURNACE

PRODUCT DATA SHEET



DIMENSIONS
Height 330mm · Width 450mm · Depth 330mm

If required the drum assembly can be detached and carried to the mould using the Combined Lifting and Pouring Tools which are supplied as optional extras.

A10 Capacity Crucible Pot

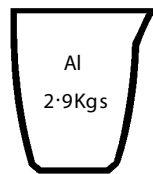

Melt times are based on Grade LM4 Aluminum and should range from 40 minutes to 60 minutes.

Flamefast can supply Grade LM4 Aluminium
Order Part No 18A14

According to the Health & Safety at Work Act 1974, BS 4163 and COSHH Regulations it is mandatory that all fumes must be removed at source.

◆ Please state type of gas when ordering ◆

PIEH TOOL COMPANY, INC.

437 W. Hwy 260, D
CAMP VERDE, AZ 86322 USA
928-554-0700 FAX: 928-554-0800
WWW.PIEHTOOLCO.COM

THIS EASY TO USE FURNACE IS IDEAL FOR FAST MELTS OF ALUMINIUM.

IT INCORPORATES THE FLAMEFAST TILT AND POUR PRINCIPLE, LEADING TO SAFER METAL POURING AND EXTENDED CRUCIBLE LIFE.

PERFORMANCE

GAS TYPE	RATE	BTU/Hr	Kw	Pressure
Natural	0.94m ³ /h	34500	10.1	20 mbar
Propane	0.7kg/h	34500	10.1	35 mbar
Butane	0.68kg/h	34500	10.1	28 mbar
Maximum Temperature				950-1000C
Electric s				Not Required
Weight				20 Kg

STANDARD EQUIPMENT

- ◆ Piezo ignition and flame failure device.
- ◆ Super efficient insulation.
- ◆ A10 capacity crucible pot.
- ◆ Crucible lid.
- ◆ Tilt handle.
- ◆ Pouring gauge.
- ◆ Degassing plunger.
- ◆ Skimming ladle/dross lifter.
- ◆ Safety bumer.
- ◆ Cut-out prevents bumer from operating when the drum is tilted.
- ◆ Operation/Instruction manual.

OPTIONAL EXTRAS

- ◆ Replacement A10 crucible pot and lid.
- ◆ Raised sand tray, 1200 x 800 x 300 mm, removes the need for a casting pit
- ◆ Face shield.
- ◆ Heat resistant gloves.
- ◆ Chrome leather leggings.
- ◆ Chrome leather apron.
- ◆ Combined Lifting and pouring handles for multiple pours.
- ◆ Hardware support casting kit.
- ◆ Moulding bench.
- ◆ Fume extraction to meet the requirements of COSHH Regulations



JUNE 00

